

# ENQUIRY FORM–HFIBF-DST (NANO MISSION)– OPEN GLOBAL TENDER

FAX: + 91 532 2545021, 2461157

Web site: <http://www.allduniv.ac.in>

**UNIVERSITY OF ALLAHABAD**

ALLAHABAD, UP, INDIA-211002



## INVITATION TO TENDER

No: UoA/DST/NanoMission/Sci-Equip-1/2015

Date: 21/05/2015.

Dear Sirs,

**Sub: Tender for supply of "Scattering Chamber for ECR Ion Source\_HFIB Facility"-  
Reg...Our Enquiry No: UoA/DST/NanoMission/Sci-Equip-1/2015, dated:  
21.05.2015.**

**Last date for Submission : 13/06/2015 up to 11.00 hrs (IST)**

**Date of Opening : 13/06/2015 at 16:00 hrs (IST)**

We are interested in importing the following material(s) as per the given specifications. Kindly, send your quotation under two bid system viz., **Part-I Technical Bid and Part-II Commercial Bid (price bid)** confirming to our terms and conditions mentioned hereunder and under the broad ambit of GFR 2005, so as to reach this office latest by **13/06/2015 at 11:00 hrs (IST)**

Sl.No.	Description of the material(s)	Qty.
1.	<b>Scattering Chamber for ECR Ion Source_HFIB Facility as per specifications stated in the annexure</b>	1 No.

Following the GFR2005 Rules 151 and 154 the Tender document shall be published in Indian Trade Journal (ITJ), published by the Director General of Commercial Intelligence and Statistics, Kolkata and The Hindu (Delhi Edition), New Indian Express (All south Edition). Web site of University of Allahabad (<http://www.allduniv.ac.in>) shall have all its advertised tender enquiries preferably with a link with NIC web site. The prospective bidders could make use of the document downloaded from the web sites. Copies of the tender notice shall be send to the Indian embassies abroad as well as to the foreign embassies in India depending on the possibility of availability of the required goods in such countries.

 **UNIVERSITY OF ALLAHABAD, ALLAHABAD-211001, U.P. (INDIA)**  
(A Central University established by an Act, 2005 of Parliament, Govt. of India)

**NIT No.: 01/2015/UoA/NANO Technology Application Center Dated: 21/05/2015**

Sealed quotations are invited for the fabrication of **Scattering Chamber for ECR Ion Source\_HFIB Facility** as per specifications broadly outlined in tender document under DST-NanoMission Scheme, from reputed manufactures directly or through their authorized dealer on or before **13/06/2015 (11:00 hrs)**. Details are available on the website [www.allduniv.ac.in](http://www.allduniv.ac.in). **Ph.No. (0532)2461083; (0532)2462242**  
**Registrar**

▼ **DETAILS BELOW** ▼

# ENQUIRY FORM–HFIBF-DST (NANO MISSION)– OPEN GLOBAL TENDER

## OPEN TENDER NOTICE IMPORTANT DATES & TIME

- ◆ Last Date & Time For Submission : 13/06/2015 (1100 HRS)
- ◆ Date/Time of Opening of Bids : 13/06/2015 (1600 HRS)
- ◆ Venue of Bid Opening : Nanotechnology Application Centre,  
Science Faculty Campus.

[Please Go To Page No. 7-48 For Details Regarding Commercial (General/Special Terms & Conditions Etc.) at the End of the section containing Technical Specifications of the Equipments required]

### TECHNICAL SECTION: DETAILED ITEM SPECIFICATIONS

[Download (Copy/Paste) the Specifications For Which YOU Are Quoting.]

1	ITEM	Scattering Chamber for ECR Ion Source_HFIB Facility	REF. NO	UoA/DST/NanoMission/S ci-Equip-1/2015
	Qty.	ONE	Bid Type	TWO BID

#### GENERAL SPECIFICATIONS:

The scattering chamber will be connected with beam line from a Full Permanent Magnet ECR In Source (ECRIS) mounted in a 300 kV platform.

The **Scattering Chamber** shall be preferred that includes the chamber with hydraulic lifting lid, sample holders, vacuum component (including turbo molecular and dry pumps, gauges), goniometer head having -Y-Z- $\theta$  and  $\phi$  rotation with command and control, software and all ancillary equipment for running the facility. **If applying for one sub system or only few components the bidder should clearly mention the novelty and advantages of theirs as why one should prefer them against other.**

Allahabad University will provide all conditions for smooth installation, including water, electricity, compressed air and equipments necessary for lifting and moving the components for installation. However, complete specifications for pre installation requirements relating to successful commissioning and operation of equipment such as power lines, HV insulation transformer, Water cooling unit, Ground, LAN etc must be provided with the Technical bid in advance.

The bidder should also provide full documentation including the necessary drawings for maintenance and training of at least 3 operators.

All drawings of the final system should be approved by the Contracting authority.

#### SPECIFICATIONS OF VARIOUS EQUIPMENTS:

1. The draft drawing of the experimental chamber is given in **FIGURE 1** (ONLY INDICATIVE). Vacuum should be guaranteed for  $1 \times 10^{-9}$  Torr. All flanges should be standard CF. The sample holders must be capable of following:
  - i. For irradiation of large number of samples arranged and optimised on a ladder (both side) in such a way that without affecting the vacuum system a number of samples could be remotely seen and moved for implantation purposes.
  - ii. For nano-structuring, uniform implantation (comparing and contrasting as in case of PIII), the sample mounted on goniometer head should be capable of receiving the beam for designated movements with variable speeds in x-y-z directions, remotely monitored and manipulated in prescribed direction. The goniometer head should be of following specifications or better:  
Adjustable axes: R $\theta$ , R $\phi$ , Y, X, Z, Range X (mm): +/- 3, Range Y (mm): +/- 3, Range Z (mm): 2.5, Range R $\theta$  ( $^{\circ}$ ): + 80 ... - 30, Range R $\phi$  ( $^{\circ}$ ): +/- 17, Read out accuracy ( $^{\circ}$ ): 0.1
  - iii. The possibility for movement of samples from one chamber to other with the help of manipulators without breaking the experimental conditions.
  - iv. The possibility for varying the temperature of sample during the irradiation. Must to operate with closed cycle cryogenic system for sample temperature variation from less than 20K to 300K and high temperature oven 300K to 1273K with respect to time, field and low and high temperature. It should consist of closed loop variable temperature cryostat and high temperature furnace with temperature controller. Closed cycle cryogenic system with cooling power of 5 watt at 20K and with Beryllium copper sample chamber. The variable temperature cryostat should be capable of generating temperatures in the range of 80-400 K with the temperature accuracy of +1 K. Lower temperature capability is preferred. Low temperature Cryostat usable with liquid nitrogen or liquid helium and

temperature variation continuously from 77K or 4.5k to 300K The high temperature oven should be capable of generating temperatures in the range of RT – 1200 K or better with temperature accuracy of + 1 K. Higher temperature capabilities are preferred. Combined cryostat and oven for the temperature variation from 77K to 900K, with LN2 the temperature variation from 77 K to 300K sable measurements should be at 77K, 90K continuous to 300k.

- v. The desirability of ii and iv simultaneously could also be worked out.
  - vi. Two gate valves for Ultra High Vacuum (UHV) with stainless steel bellows sealed: Gate Valve Optional Features include: Modular electromechanical position indicators, Air control solenoid valves, stainless steel bellows, High body roughing ports and High temperature. They must be bellows sealed and their mechanism should be free of lubricants.
2. **Portable He gas leak detector system:** The detection range of Helium in vacuum tests lies between  $10^{-2}$  and  $10^{-11}$  Pa.m<sup>3</sup>/s or better.
  3. **Vacuum components:** Vacuum components, including Turbo-molecular pumps, Cryogenic pumps, mechanical pumps, connections, vacuum measurements, bellows, isolation valves and vacuum measurements must be provided. Remote control is not required, but remote vacuum measurements should be included in the Command and Control system. The vacuum pressure in the experimental chamber (without beam) should be of  $1 \times 10^{-9}$  Torr.
  4. **Documentation:** Operation & Service manuals in Duplicate: Full documentation of all components should be provided in English. The documentation should include functional description, maintenance procedure and troubleshooting, Diagrams of electrical wiring & interconnections and Electronic Circuits (including those of sub assemblies), Spatial and temporal mapping related to measurements of emanating radiations from the equipment and any warning or mitigation issue during the operation or maintenance of equipment, in Duplicate.
  5. **Installation and training:** The installation of the whole system should be executed by the bidder. The Contracting authority will provide substantial help and all local conditions for the installation provided all the inputs relating to technical specifications for the same is furnished along with the technical bid by the bidder. The training should be included that will occur in the final place of the equipment, after final tests. The installation and commissioning will be carried out at UOA, ALLAHABAD by the firm's engineers. Special utility requirements, such as, vibration free platform, power points, cooling water, LN2 consumption, etc., should be informed well in advance for necessary site preparation.
  6. **Quality:** The bidder should demonstrate ultimate vacuum achieved in scattering chamber. This test should be done in the factory and at on-site after the installation. Conditions for the tests and acceptance will be mutually agreeable between contracting authority and the bidder.
  7. **Guarantee/Warranty**  
The complete system must be guaranteed for free repair/replacement for a minimum period of five year from the date of satisfactory installation and acceptance. Software up gradation, if any, has to be incorporated free of cost during the warranty period.
  8. **The itemized details of the equipment and its components** must contain the technical specifications (**and their itemized prices in financial bid**) to be able to compare, contrast and select as per the project objectives for example:
    - j) The system should be complete with power supplies, controls for remote operation, cooling lines and cabling.

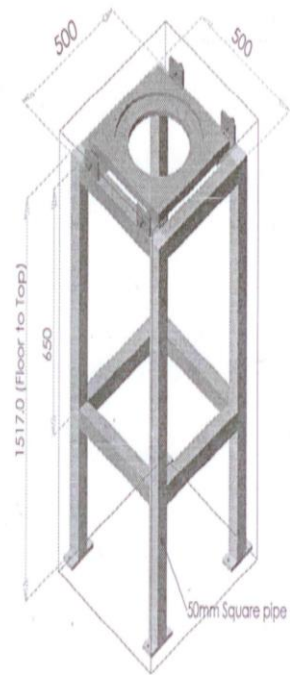
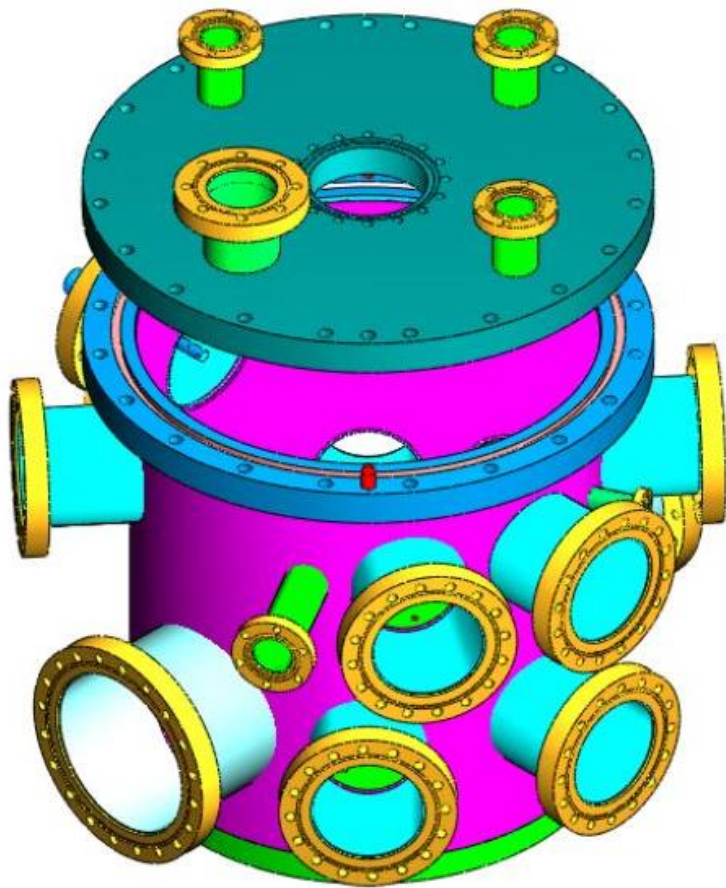

FIGURE -1

**Important: Please provide a compliance statement of the specifications along with the quotation by responding to each and every specification detailed as per above.**

## **COMMERCIAL SECTION: DETAILED TERMS & CONDITIONS**

### **GENERAL CONDITIONS**

**1. SEALED TENDERS are invited** from the **Original Equipment Manufacturers** having local operations in India. System integrators with exclusive authorized rights and accredited / authorized sole selling Representatives in India are also eligible to quote against this for the supply, installation and commissioning of the equipments listed under **TWO BID SYSTEM\***. i.e. such offer must be submitted in **two separate sealed envelopes**, one containing **Technical Bid along with EMD** and second containing **PRICE Bid**. The outer envelopes must specify the TECHNICAL/PRICE bid, as the case may be. *Under no circumstances the two quotes should be kept in a single envelope.*

\*

- a) **ENVELOPE I (Technical Offer)**: The Technical offer should be complete in all respects and contain all information asked for, **except prices**. The Technical offer should include all details on specifications asked for in **Annexure IX**. For example, Technical Offer should mention that 3 Years Warranty Period is included in the Commercial offer, without mentioning the actual amounts in the Technical offer. The suggested format for submission of technical offer is as follows:
- (i) All documents & certificates listed under "**Eligibility Criteria**" on Serial No. 2 of this tender document to be attached by the Bidder.
  - (ii) Covering letter as per **Annexure I** & Check List with **Technical Bid**
  - (iii) EMD in the form of Valid Bank Guarantee/demand draft as per **Annexure II**
  - (iv) Manufacturer's Authorization Form (if applicable) as per **Annexure III**
  - (v) The Company profile as per **Annexure IV and Annexure V**
  - (vi) Details of 3 major projects as per **Annexure VI**
  - (vii) Details of Support / Service Centers as per **Annexure VII**
  - (viii) Bidder's Financial Details (audited balance sheets etc.) and other supporting documents, as asked in the tender document.
  - (ix) Warranty compliance statement in **Annexure VIII**
  - (x) **TECHNICAL OFFER FOR THE LISTED SPECIFICATIONS** given on page 2-4 with all the columns filled in. **This should not contain any price information.**
  - (xi) Deviation table as per **Annexure IX**.
  - (xii) **Questionnaires' I, II, III**
  - (xiii) Technical Documentation (Printed product Brochures and all technical leaflets, etc.) to be attached compulsorily with the Technical offer.
- b) **ENVELOPE II (Commercial Offer)**: The Commercial Offer (C.O) should give all relevant price information as per **Annexure X**. The Bid Form must be filled in completely, without any errors, erasures or alterations. The Commercial offer must not contradict the technical offer in any way. A Brief Summary of Quotation **should also be included with Price Bid**.
- c) **After scrutiny and evaluation of technical bids, a technical comparative statement will be prepared ranking in the highest and in that order of descending**. The technically superior bids only will be considered for commercial comparison. **The decision of UoA shall be final in this regard.**

**2. ELIGIBILITY CRITERIA: ORIGINAL EQUIPMENT MANUFACTURERS** should have executed similar supplies in India including with Universities/CSIR Laboratories/DAE Laboratories/ Institutes/IITs/IISc etc with at least 3 organisations. The bidder should have reputed background and should be established in the business for at least 5 years. For the three years out of the last five years, the turnover should be at least Rs 10 Crores (INR Ten Crores) (Globally). Bidder must be a registered corporate entity in India. In case of companies incorporated outside India, they should mention an authorized service entity, who would provide post purchase services on behalf of its principal. Bidder should be a registered OEM or Authorized dealer on behalf of such manufacturer having at least 5 years valid manufacturing license issued by Govt.of India. (Please attach copy of the same). Bidder having an ISO 9001 and ISO 14001 certification shall be preferred (Please enclose copy of relevant certifications). Bidder should have been making profits during 3 years out of last 5 years. Audited Balance sheet and Profit and Loss account (amount in Rupees) for last three years should be

## ENQUIRY FORM–HFIBF-DST (NANO MISSION)– OPEN GLOBAL TENDER

submitted. In addition, the University may ask for Income Tax Returns of the bidders if it deems necessary. Documentary evidence is to be submitted for these 3 projects with contact details, name, Tel Nos. and Fax. Nos. of the previous customers. A complete list of all other places where **similar/same equipment** has been supplied by the bidder is also desired. Certificate of EMI compliance for their products as per EN standard EN50091-2 from Electronics Regional Testing Laboratory (ERTL)/Society for Applied Microwave Electronics Engineering and Research-SAMEER or equivalent international entity should be enclosed. The party must give an undertaking for submitting the certificate EN50091-1 for safety and EN50091-2 for EMC compliance to be enclosed. The **Profile of the organization/** firm should be enclosed in the Technical bid with reference to domain expertise/ user base etc.

**3. TENDER DOCUMENTS** can be downloaded from websites <http://www.allduniv.ac.in>, <http://www.alldunivpio.org> and can also be obtained in person on payment of the document cost by way of a DD Rs 1000.00 (Rs One thousand) issued from Nationalised bank drawn in favour of **The Finance Officer, Allahabad University payable at Allahabad**. If Tender Document is required **by post then add additional Rs.100/- to the T.D. Cost**. The same may be forwarded along with the request letter. The postal delay, if any, shall not be the responsibility of UoA.

**i) SUBMISSION OF TENDER:** The bidders in their own interest are requested to send their offers by Registered Air Mail Post instead of by air parcel to avoid delay in clearance. While forwarding the tender documents by Air Mail post they should clearly indicate on the packet that the same contains only tender documents. The purchaser will not be responsible for any delay caused by the dispatch of tenders by Air parcel through the Airlines as the clearance of such packets from the Customs involves unavoidable cumbersome procedure. The tenders received after the specified date and time will be considered as late tender and will not be opened.

**ii) LATEST HOUR FOR RECEIPT OF TENDER**

The tender must reach the Prof Avinash C Pandey, **Principal Investigator (HFIBF), Nanotechnology Application Centre, University of Allahabad** not later than the specified date and time as under:

(i) Before 11.00 AM of 13/06/2015

(ii) The Technical Part of tender will be opened on the date and time specified as under:

4.00 PM on 13/06/2015

(iii) The bidders and their authorised representative are at liberty to be present at the time of opening of the tender at **Nanotechnology Application Centre, University of Allahabad-211002**.

**iii) PERIOD FOR WHICH OFFER WILL REMAIN OPEN:** The tender shall remain open for acceptance until the date stipulated in Tender Notice. **If any unscheduled holiday occurs on the date of closing/opening, then next working day shall be the prescribed date of closing/opening. Requests for postponement will not be entertained.** Fax/email bids may not be accepted. Late/Delayed tenders shall not be opened.

**4. PLEASE STRICTLY ADHERE TO THE DATES/TIMES MENTIONED IN THIS DOCUMENT ABOVE.**

**5. NO UNSOLICITED CORRESPONDENCE SHALL BE ENTERTAINED.**

**6. EARNEST MONEY DEPOSIT (EMD):** A demand draft issued from any nationalized bank towards as EMD of Rs 2,00,000.00 (Two Lac INR) amount drawn in favour of **Finance Officer, University of Allahabad, payable at Allahabad** must be enclosed with the Technical Bid and PHOTOCOPY of the same to be enclosed with PRICE BID. The EMD shall not earn any interest. The EMD of unsuccessful bidders shall be returned after award of contract. All tenders received without EMD shall be summarily rejected. **SSI Units** registered with NSIC who enjoy the exemption will be **allowed exemption from only EMD & not for submission of Performance Bank Guarantee**. Firms registered with Govt. PSUs are not exempted from payment of EMD. EMD will be confiscated in case of breach of trust.

**7. SPECIFICATIONS are basic essence of the product. It must be ensured that the offers are strictly as per our specifications.** At the same time it must also be kept in mind that merely copying our specifications in their quotation shall not make firms eligible for consideration. A quotation has to be supported with the printed technical leaflet/literature (wherever applicable and available like in case of scientific items, misc. IT/Office products, readymade furniture) and the specifications mentioned in the quotation must be reflected/supported by such printed technical leaflet/literature model quoted/tendered specifications

## ENQUIRY FORM–HFIBF-DST (NANO MISSION)– OPEN GLOBAL TENDER

should invariably be highlighted in the leaflet/literature for easy reference. **Please also make and attach with your quotation the technical compliance sheet as per the format given in Annexure I for proper evaluation at our end.** In the event of any ambiguity/confusion on account of item specification/description, the offer will be **rejected** without giving the quoting firm any opportunity for clarification/negotiation. Accordingly technically unsuitable offers, offers not confirming to tender schedule or offers from defaulters etc. will also be rejected. **Please mention if there are any other special features that have not been covered above which in your opinion is a uniqueness of your product.**

### **8. THE BASIC PRICES SHOULD BE QUOTED IN FOB ONLY. The offer should include the following:**

- i) Prices quoted Cost of the component (sub-system) wise itemized equipment (to finer details as far as possible) inclusive of all **taxes & statutory levies** and charges for onsite installations in the campus of University of Allahabad.
- ii) The itemised price also required to be quoted on Ex-works and/or FCA (*inclusive of necessary export packing cost*), **5 years onsite comprehensive warranty** covering all parts & labours. This period will start from the date of installation and successful acceptance of all the goods by the University of Allahabad. This does not include the applicable duties & taxes.
- iii) The price quoted in the tender required to be quoted in ink, both in figures & words. In case of any Discrepancy, the rate quoted in figures will be accepted.
- iv) The price validity of the quotation should not be less than six months from the date of opening of the tender.
- v) The University shall provide Excise duty exemption certificate and custom duty exemption certificates on imported/custom bonded items (if any), but not the concession certificates towards the exemption of sale tax or any other incidents of tax.
- vi) Insurance to cover equipment up to the site of installation & successful acceptance of the equipment at University of Allahabad.
- vii) Special discounts/rebates, wherever applicable, keeping in view that the supplies are being made to an educational institution, may please be indicated.
- viii) **Wherever applicable, rates under duty exemption/high sea sales agreement should be quoted. The Quotes for this should be in US Dollars/ GBP/ Japanese Yen/ Euro only. For the purposes of comparison, the exchange rate applicable on the day of Financial Bid opening will be taken.**
- ix) Bidders should have all documents containing permission for manufacture, export to India etc. Further, the bidder should obtain permissions at their cost for Import/Export/Clearance from country of origin.
- x) Prices must be firm and on FOB basis. Different components of prices for insurance, freight, installation and commissioning at destination site, discount if any, should be shown separately. While quoting rate per unit specified in the schedule, bidders are required to give total cost as well. If it is decided to ask reimbursement of excise duty or any other charges as extra, the same must be specifically quoted.
- xi) Prices should be shown separately for each item (foreign exchange component/rupee element) viz. Basic unit, its accessories, computer, software, and critical spares/components. **Offers not indicating item wise prices are liable to be rejected.** The offer should be valid for a period of 180 days from the specified date of opening.

**9. LIQUIDATED DAMAGES:** In case of supply order for the SCIENTIFIC EQUIPMENTS/ APPARATUS, the date of delivery should be strictly adhered to otherwise, UNIVERSITY OF ALLAHABAD reserves the right not to accept delivery in part or full and claim liquidated damages of 0.5% per week subject to maximum of 5% of the total value of supply order.

**10. PRINTED CONDITIONS OF THE QUOTATION SHALL NOT BE BINDING ON US.** Quotation must be clearly written or typed without any cutting or over-writing. All cutting/over-writings must be initialed and stamped.

**11. CONDITIONAL AND AMBIGUOUS TENDERS** etc. shall not be accepted. Rates quoted without attached conditions (viz. Discounts having linkages to quantity, payment terms etc.) will only be considered for evaluation purpose. Thus conditional discounted rates linked to quantities and prompt/advance payment etc, will be ignored for determining *inter-se* position. University of Allahabad, however, reserves the right to use the discounted rate/rates considered workable and appropriate for counter offer to the successful bidders. The tenders qualified by

## ENQUIRY FORM–HFIBF-DST (NANO MISSION)– OPEN GLOBAL TENDER

such vague and indefinite expression such, 'subject to immediate acceptance' 'subject to prior sale' will not be considered.

**12. THE ACCEPTANCE OF THE QUOTATION/offer will rest with University of Allahabad, it does not bind itself to accept the lowest quotation and reserves the right to himself to reject or partially accept any or all the quotations received, or to waive off any condition without assigning any reason.**

### 13. EXPERIENCE:

Details of the client list for supplying similar type of instruments have to be submitted. If the bidder has supplied identical or similar equipment to other Universities/CSIR labs/Institutes, the details of such supplies for the preceding three years shall be given together with the prices eventually or finally paid. **(Prices to be disclosed in PRICE bid only).** Provide the list of users in India, particularly Central Universities / CSIR Laboratories/ Institutes / IITs / IISc, along with their complete address including fax, e-mail etc. Also enclose performance certificate.

### 14. NONTRANSFERABLE TENDER

This tender document is not transferable. Only the bidder, who has purchased this tender, is entitled to quote. Any change in the constitution of the firm, etc. shall be notified forthwith by the contractor in writing to the tendering authority and such change shall not relieve any former member of the firm, etc., from any liability under the contract. No new partner / partners shall be accepted in the firm by the contractor in respect of the contract unless he / they agree to abide by all its terms and conditions, and deposits with the tendering authority a written agreement to this effect. The contractor's receipt for acknowledgement or that of any partners subsequently accepted as above shall bind all of them and will be sufficient discharge for any of the purpose of the contract.

### 15. CLARIFICATION OF OFFERS

To assist in the scrutiny, evaluation and comparison of offers, University of Allahabad may, at its discretion, can ask some or all bidders for clarification of their offer. The request for such clarifications and the response will necessarily be in writing. If deemed necessary, the bidder is required to give a presentation / arrange a demo of the items offered at the venue decided by the University of Allahabad.

**16. TECHNICAL INSPECTION AND PERFORMANCE EVALUATION** University of Allahabad reserves its right to carry out a technical inspection and performance evaluation of equipment offered by short listed bidders.

**17. PRELIMINARY SCRUTINY** University of Allahabad will scrutinize the offers to determine whether they are complete, whether any errors have been made in the offer, whether the required technical documentation has been furnished, whether the documents have been properly signed, and whether items are quoted as per the schedule. The University of Allahabad may, at its discretion, waive any minor nonconformity or any minor irregularity in an offer. This shall be binding on all bidders and University of Allahabad reserves the right for such waivers.

**18. ERASURES OR ALTERATIONS** The offers containing unauthenticated erasures or alterations will not be considered. There should be no unauthenticated handwritten material, corrections or alterations in the offer. Technical details must be completely filled up. Correct technical information of the product being offered must be filled in. University of Allahabad may treat offers not adhering to these guidelines as unacceptable.

**19. MODIFICATIONS AND WITHDRAWAL OF OFFERS** The bidder may modify or withdraw its offer after its submission, provided that written notice of the modification or withdrawal is received by University of Allahabad **prior to the closing date and time prescribed** for submission of offers. No offer can be modified by the bidder, subsequent to the closing date and time for submission of offers. In the event of withdrawal of the offer by successful bidders, the EMD will not be refunded by the University.

**20. NO COMMITMENT TO ACCEPT LOWEST OR ANY TENDER** University of Allahabad shall be under no obligation to accept the lowest or any other offer received in response to this tender notice and shall be entitled to reject any or all offers including those received late or incomplete offers without assigning any reason whatsoever. University of Allahabad reserves the right to make any changes in the terms and conditions of purchase. University of Allahabad will not be obliged to meet and have discussions with any bidder, and or to listen to any representations.



## ENQUIRY FORM–HFIBF-DST (NANO MISSION)– OPEN GLOBAL TENDER

### 21. PACKING AND MARKING

- i) Packing: The supplier will ensure that the stores are securely packed to avoid damage in transit by sea/air/rail/road occasioned by any defect in packing and shipping documents should also show the name of the ultimate consignee.
- ii) The supplier shall insert in each case packing list fully item-wise to show the case number, contents, gross and net weight and cubic measurement and dimensions. Four copies of each packing list shall be supplied to the forwarding Representative.
- iii) Marking: Each Case shall have shipping marks stenciled on two opposite side and on the top. In addition, the gross weight/net weight and cubic measurements should also be indicated on the packages. The marks shall also be shown on invoices, packing lists and on rail/road bills of lading or mailing certificates exactly as they appear on the cases.
- iv) The purchaser reserves the right to give a purchase/price preference to offers from Indian Public Sector Units and /or from other firms in accordance with the policies of Government of India from time to time.

### 22. BANK CHARGES: -

The bank charges will be charged inside India to the applicant account and outside India to the beneficiary account.

### 23. AGENT:

An Indian agent, if any, who will participate in this Tender on behalf of one manufacturer, will not be eligible to represent another manufacturer.

#### : PLEASE NOTE:

**TWO BID** means that MAIN ENVELOPE contains following TWO Envelopes

1. **TECHNICAL BID Envelope contains:** EMD in Original (if Applicable), All Technical Details/Brochures/ Leaflets, COMPLIANCE STATEMENT, COMMERCIAL TERMS like Payment, Delivery, Warranty, etc. **(Please Note That If EMD, Wherever Required, is NOT found Enclosed With This Envelope, Your Offer Shall Be Rejected Summarily)** QUESTIONNAIRE I, II & III ON FINANCIAL & OTHER ASPECTS and Annexure I to IX, they should be duly filled up and returned along with the each of the proposal (Technical Bid).
2. **PRICE/COMMERCIAL BID Envelope contains:** Photocopy of the EMD DD, Summary/Checklist Page, Price Quote in Detail for individual components and the total price, discount, taxes, delivery charges, FOB, Documentation Charges, Handling Charges, Insurance, Training, Installation charges or any other chargeable expense related to the supply, installation and commissioning of the item.
  - I. Prices for the spare parts should be quoted on FOB Air Port Basis
  - II. Insurance and Freight charges till destination site i.e. UoA, Allahabad should be shown separately.
  - III. For Stores supplied ex-stock in India, ex-stock price and charges for freight the stores to destination should be indicated.
  - IV. Discount (if any) should be indicated prominently.
  - V. Tenderer should furnish a clear declaration as follows: All our imports are under OGL and we are exempted for payment of extra Custom Duty. Please confirm that the item is not in the negative list.
  - VI. Wherever it is possible, insurance and transportation will be done through Govt. of India Agencies, GIC/Shipping Corporation of India/Air India Ltd. etc

**SPECIAL CONDITIONS**

1. For import items kindly quote **ONLY** in **USD (\$), Euro (€), Yen (¥), GBP (£)** wherever possible for correct evaluation during comparison. The validity of the offer should not be less than **180** days.
2. For **imported items**, mention the price of the goods on FCA/FOB basis. The comparison of bids will be done on FOB basis. **CIF/CIP rates for shipping items up to Allahabad (India) preferably through India's National Airline Carrier AIR INDIA should also be mentioned.** If facility of Air-India is not available in your country, specific intimation to this effect should be mentioned in your Performa Invoice. **Please also indicate approximate shipment (packed) weight & dimensions of the item quoted by you. Please note that all FCA orders will be on FCA (International Carrier) INCOTERMS 2000 basis and as such Export Packing, Loading Charges, Inland Freight etc. in the shipper country will have to be paid by the Supplier. Items as per the purchase order duly cleared for export in shipping country would be required to be handed over to our nominated freight forwarder.** FOB price quotes will be preferred over FCA price quotes. However if required, University of Allahabad reserves the right to place the order on quoted CIF/CIP basis also.
3. Items are to be Packed, Marked & Labeled as per international norms. Small individual boxes must be **palletized** for easy handling & movement. Therefore state packing/ forwarding/ documentation charges etc. (each one) separately, if applicable.
4. **For indigenous supplies** payment will be made by Account payee cheque only, after receipt of the stores in good condition after testing and acceptance. **For Import LC**, all the bank charges outside India will be borne by the supplier. Charges for confirmation, any extension or amendments to LC at the request of the supplier will also have to be borne by the beneficiary (supplier). **We discourage on sight draft payments and may accept time (dated) draft payments. Advance payment terms will not be accepted unless it relates to turn key system and as per the GFR 159 (1) and ceiling imposed therein as stated above.** However FDD towards 100% payment can be kept ready and released on receipt of stores in good working condition after testing and acceptance. In this case on receipt of your Order Acknowledgement an FDD will be made a photocopy of which will be sent to you to enable you to ship the material. On satisfactory receipt and acceptance of the materials or satisfactory installation and commissioning of the equipment the Original FDD will be sent to you/handed over to your Indian representative.
5. In case the quotation is submitted by **Indian Representative**, the same must be accompanied by valid authorization letter from principals.
6. Indian Representatives of the foreign supplier must be registered with Director General of Supplies and Disposal (**DGS&D**), for the import of items mentioned in the **restricted** list of import. One Representative cannot represent more than one suppliers/principals or quote on their behalf for the same item.
7. If the items are not covered under **Open General License (OGL)** of EXIM POLICY (2002-2007), the supplier should obtain prior Special Import License (SIL) from DGFT at their own cost; otherwise demurrage accrued due to delay in the clearance of consignment will be your responsibility.
8. Unconditional **Performance Bank Guarantee (PBG)** of 10% of order value will have to be submitted on the prescribed format, valid till 60 days after the warranty period from a nationalized bank within 21 days of the placement of order where payment is to be released on L/C or on delivery, failing which the contract shall be deemed as terminated. In cases where part payment is to be made on delivery & part on installation, the Performance BG shall have to be submitted at the time of release of final payment. EMD will be released on submission of the PBG.
9. Please ensure that quoted price is not more than the price offered to any other customer in India to whom this particular item has been sold, particularly to Universities/CSIR Labs/Institutes and other Government Organization. Copy of the latest price list for the quoted item, applicable in India, must be enclosed with your offer in Price Bid.
10. **TECHNOLOGY CERTIFICATE:** The supplier should issue a certificate stating that
  - a. The equipment is of latest technology.
  - b. The equipment may be upgraded as and when required by UNIVERSITY OF ALLAHABAD and

## ENQUIRY FORM–HFIBF-DST (NANO MISSION)– OPEN GLOBAL TENDER

- c. The equipment will be promptly and properly serviced by them whenever desired by UNIVERSITY OF ALLAHABAD within 10 years after its procurement by UNIVERSITY OF ALLAHABAD.
11. For **Two Bid** enquires offer must be submitted in two separate envelopes, one containing Technical bid along with EMD and second containing PRICE bid, duly sealed from outside and kept in an envelope. The outer envelope must specify the technical/PRICE bid, as the case may be.
  12. The PRICE bid must mention the **prices of all items** of particular equipment asked for individually and then summed up at last i.e. package deal for all items which are essential for the system as per our tender. Optional items asked for can be submitted separately in the PRICE bid.
  13. We may ask for the **Inspection Report** to be provided by the Agency nominated by us charges for which will have to be borne by you.
  14. **Pre-installation requisites** (electrical/floor/space/air-conditioning etc.) if any should invariably be mentioned clearly. Installation/ Training will be the full responsibility of the supplier/ Indian Representative.
  15. If any short-shipment etc. is noticed, the same will be arranged immediately with all charges to this effect to be borne by supplier/Indian Representative.
  16. Transshipment or partial shipment not allowed.
  17. **In case of indigenous supplies**, the goods should be insured against theft, loss or breakage during transit and insurance charges should not exceed 1% of the cost of material supplied, the rates of Sales Tax, Excise Duty etc. (as applicable) should be clearly indicated. Form C & D is not applicable to us. However, we are exempted from payment of Excise Duty and certificate to this effect can be provided. We can also consider issuing of "*Concessional Sales Tax Certificate*" wherever applicable.
  18. All items should carry normal **warranty** period of at least five year from date of installation. Therefore Warranty/Guarantee period should be mentioned clearly in the offer. Please quote tentative Annual Maintenance Charges (AMC Charges) (may be of %age of FOB value), if any, after warranty/Guarantee period is over.
  19. **SPARE PARTS:** Tenderers should include in their tender provision for tools and initial stock of maintenance spares as are essential for proper operation and maintenance of the equipment. Full particulars of spare parts should be provided separately. In addition to the above, estimated requirements of spares consumption per annum should be indicated. The successful tenderers shall warranty that spare parts for the system would be available for a minimum period of TEN (10) years after acceptance of the system/equipment. And thereafter before going out of production of the spare parts, he will give a notice prior to such discontinuation. The supplier shall be responsible to obtain all export licenses for any other Govt. authorization from their Country. Certificate of origin will have to be provided by the supplier duly signed by the Chamber of Commerce of the country concern/original supplier. **List of buyers** where similar type of equipment instrument has been supplied may also be given by the bidder. Party should provide all Interconnecting cables, Service manual and Operation manual. Suitable printed manuals must support all software (licensed) provided with all the modules and the computer hardware and software, which will be used, should be of latest versions. All specifications should be supported by printed brochure/website. The system should be provided with standard accessories, tool kit and consumables.
  20. **DELIVERY & INSTALLATION PERIOD** The University of Allahabad would like to have the following time schedule for completion of the activities from the date of placement of orders.
    - a. Delivery: 16-18 months
    - b. Installation, testing and setting up the unit for continuous operation: 8 weeks from the date of delivery/readiness of site as communicated by University.The bidder shall be responsible for proper packing so as to avoid damage under normal conditions of transport by sea, rail and road or air and delivery of the material in good condition to the consignee at destination. In the event of any loss, damage, breakage or leakage or any shortage the bidder shall be liable to make good such loss and shortage found at the checking / inspection of the material by the consignee. No extra cost on such account shall be admissible.
  21. **INSTALLATION, ERECTION, COMMISSIONING & ACCEPTANCE AT SITE:** Installation and testing of the system at our site with your Instruments, accessories, tools & tackles; deploying appropriate manpower as required, at your cost. The bidders shall be responsible for erection & installation of the equipment at destination site and for making it fully operational. Payment

## ENQUIRY FORM–HFIBF-DST (NANO MISSION)– OPEN GLOBAL TENDER

and terms and conditions, if any, for the same would be specified by the bidder separately. In this connection pre-installation requirements will be mentioned in the tender. The bidders must provide complete details regarding space and all infrastructural needs of the equipment, which UNIVERSITY OF ALLAHABAD should arrange before the arrival of equipment in UNIVERSITY OF ALLAHABAD to ensure its early installation and smooth operation thereafter. (The successful bidder may offer their advice and assistance to UNIVERSITY OF ALLAHABAD in the preparation of the site).

**22.TRAINING:** The bidders shall make provision of imparting training to our Scientists/Maintenance Engineers on operation and use of equipment, its accessories and software's for the intended applications and trouble shooting repair and maintenance. Cost if any for such training and the details regarding the course covered and its duration should be specified.

**23.EXCISE DUTY:**

This Organisation is exempted from the payment of Excise Duty against Govt. of India Notification No. 10/97 Central Excise dated 1<sup>st</sup> March, 1997 under DGSIR Registration No. TU/V/RG-CDE (396/2005) dated 26/09/2005 hence excise duty chargeable should be shown separately in the offer. Excise Duty Exemption can be availed on :

- a. Scientific & Technical Instruments, apparatus, equipments including Computers.
- b. Accessories & spare parts of goods specified above and consumables.
- c. Computer Software, CD-ROM, recorded magnetic tapes, microfilms, microfiches.
- d. Prototype where cost do not exceed Rs.50,000/-

**24.CUSTOM DUTY:** University of Allahabad being the Teaching and Research organization is exempted from paying custom duty vide notification no. 51/96 DATED 23.07.1996 on the equipment imported for research purpose. Additional 5.15% custom duty shall be paid by us at the time of clearance of goods from customs; hence custom duty should not be included in the bill. Certificate to this effect should be provided by UoA.

**25.INCOME TAX** may be deducted at source as per rules.

**26.TERMS OF PAYMENT**

- a. NO ADVANCE PAYMENT WITH THE ORDER WILL BE MADE **OR** BEFORE DESPATCH OF THE GOODS. ORDINARILY, PAYMENTS FOR SERVICES RENDERED OR SUPPLIES MADE SHOULD BE RELEASED ONLY AFTER THE SERVICES HAVE BEEN RENDERED OR SUPPLIES MADE. HOWEVER AS PER **RULE 159 (1) [GFR2005] AN ADVANCE PAYMENT TO THE SUPPLIER SHALL BE ADMISSIBLE IF IT BECOMES NECESSARY IN THE FOLLOWING TYPES OF CASES:-**

(I) ADVANCE PAYMENT DEMANDED BY FIRMS HOLDING MAINTENANCE CONTRACTS FOR SERVICING OF AIR-CONDITIONERS, COMPUTERS, OTHER COSTLY EQUIPMENT, ETC.

(II) ADVANCE PAYMENT DEMANDED BY FIRMS AGAINST FABRICATION CONTRACTS, TURN-KEY CONTRACTS ETC. SUCH ADVANCE PAYMENTS **SHOULD NOT EXCEED** THE FOLLOWING LIMITS:

- THIRTY PER CENT. OF THE CONTRACT VALUE TO PRIVATE FIRMS;
- FORTY PER CENT. OF THE CONTRACT VALUE TO A STATE OR CENTRAL GOVERNMENT AGENCY OR A PUBLIC SECTOR UNDERTAKING; OR
- IN CASE OF MAINTENANCE CONTRACT, THE AMOUNT SHOULD NOT EXCEED THE AMOUNT PAYABLE FOR SIX MONTHS UNDER THE CONTRACT.

**WHILE ASKING ANY ADVANCE PAYMENT AS ABOVE, THE FIRM SHALL HAVE TO PROVIDE RECEIPTS OF COMPONENTS PROCURED FOR THE FABRICATION AND MUST FURNISH BANK GUARANTEE FOR THE SAME VALUE FROM THE NATIONALISED BANK OF INDIA.**

- b. **PART PAYMENT TO SUPPLIERS:** DEPENDING ON THE TERMS OF DELIVERY INCORPORATED IN A CONTRACT, PART PAYMENT TO THE SUPPLIER MAY BE RELEASED AFTER IT DISPATCHES THE GOODS FROM ITS PREMISES IN TERMS OF THE CONTRACT.
- c. ALL PAYMENTS ARE MADE BY CROSSED/ACCOUNTS PAYEE CHEQUE DRAWN ON THE STATE BANK OF INDIA, ALLAHABAD UNIVERSITY BRANCH, AFTER RECEIPT OF GOODS IN GOOD CONDITION *AFTER ACCEPTANCE* TO THE INDIAN SUPPLIERS.
- d. THE TERM OF PAYMENT IS 90% AND 10% FOR BOTH INDIGENOUS AND IMPORTED ONES.THE 90% PAYMENT IN RESPECT OF IMPORTED ITEMS WILL BE MADE ON RECEIPT OF SHIPMENT DOCUMENTS IN THE BANK, THE BALANCE 10% PAYMENT WILL BE MADE AFTER THE EXPIRY OF WARRANTY PERIOD. IN THE EVENT OF SUBMISSION OF PERFORMANCE OF BANK GUARANTEE OBTAINED FROM ANY OF THE NATIONALISED BANK,

## ENQUIRY FORM–HFIBF-DST (NANO MISSION)– OPEN GLOBAL TENDER

THE BALANCE 10% PAYMENT WILL BE MADE AFTER THE SATISFACTORY INSTALLATION, TESTING & ACCEPTANCE BY UNIVERSITY OF ALLAHABAD.

- e. ONE OF THE FOLLOWING PAYMENT TERMS MAY BE AGREED WITH THE FOREIGN SUPPLIERS.
- i. **Credit basis:** The payment will be made after testing and acceptance of the goods in good condition by TT/FDD.
  - ii. **FDD:** FDD (100% of payable amount) can be kept ready for release on installation and testing. Photocopy of FDD can be sent on acknowledgement of work order.
  - iii. **Letter of Credit:** The letter of credit for 100% FOB value will be established in the supplier's country after acceptance of order with its terms by the supplier. 90% payment will be released against shipping documents and balance 10% is released after receipt of the goods in good condition/satisfactory installation (wherever necessary) at Destination & performance bank guarantee.

**27. LIQUIDATED DAMAGES:** Being a Research and Teaching Institution, time is essence of the order the date of delivery should be strictly adhered to. Otherwise, University of Allahabad reserves the right not to accept delivery in part or full and to claim the liquidated damages 0.5% per week subject to maximum 5% of FOB value of the order.

### **28. FORCE MAJEURE**

- a. The bidder shall not be liable for forfeiture of its performance security, liquidated damages or termination for default, if and to the extent that its delay in performance or other failure to perform its obligations under the contract is the result of an event of force Majeure. For purposes of this Clause, "Force Majeure" means an event beyond the control of the Bidder and not involving the bidder's fault or negligence and not foreseeable. Such events may include, but are not limited to, Acts of God or of public enemy, acts of Government of India in their sovereign capacity, acts of war, acts of University of Allahabad in fires, floods and freight embargoes.
- b. If a Force Majeure situation arises, the Bidder shall promptly notify University of Allahabad in writing of such conditions and the cause thereof within twenty calendar days unless otherwise directed by University of Allahabad in writing, the Bidder shall continue to perform its obligations under the Contract as far as it is reasonably practical, and shall seek all reasonable alternative means for performance not prevented by the Force Majeure event. In such a case, the time for performance shall be extended by a period(s) not less than the duration of such delay. If the duration of delay continues beyond a period of three months, University of Allahabad and the bidder shall hold consultations with each other in an endeavor to find a solution to the problem. Notwithstanding above, the decision of University of Allahabad shall be final and binding on the bidder.

**29. MERGER & ACQUISITION:** In the event of amalgamation of quoted firm with another one during the tenure of the contract period, the responsibility to execute the order fully with all future obligations shall rest with the bidder till the expiry of tenure.

**30. PERFORMANCE BANK GUARANTEE:** University of Allahabad reserves the right to insist for the performance bank guarantee for 10% FOB value of Scientific Equipment/Instruments valid at least for warranty period after the satisfactory installation/commission of the equipment/instrument by you/your Indian Representatives. The performance bank guarantee is also to be furnished of 10% value for indigenous purchases. The Performance Guarantee where-ever required (at least for warranty period) can be insisted upon & Supplier/their Representatives must agree for the same

**31. TERMS AND CONDITIONS OF TENDERING FIRMS:** Printed terms and conditions of the bidders will not be considered as forming part of their tenders. In case terms and conditions of the contract applicable to this invitation to tender are not acceptable to any bidder, he should clearly specify deviation in this tender. The UNIVERSITY OF ALLAHABAD reserves the right to accept or reject them. University of Allahabad, shall not be bound to give reasons for his refusal to consider the tender with such deviations.

### **32. SIGNING OF TENDER**

Individual signing the tender or other documents in connection with the contract must specify whether he signs as:

- a. a 'Sole Proprietor' of the firm or constituted attorney of such sole proprietor.
- b. *Constituted attorney of the firm*, if it is a company

## ENQUIRY FORM–HFIBF-DST (NANO MISSION)– OPEN GLOBAL TENDER

- c. *Indian Representatives:* An authority letter from their Principals will have to be enclosed with the technical bids from their Principals that the Indian Representatives namely\_\_\_\_\_ is authorized to submit the tender on their behalf and the rates/terms settled by them will be binding on the Principals (supplier).
- d. *It will be appropriate that an authority letter from the supplier on whom the Tender is being sent must be enclosed with the offer failing which their offer may not be considered without further correspondence. The Authority Letter must clearly specify that the supplier will accept the terms and conditions settled by their Representatives.*

### **33. INSTRUCTIONS FOR SOLE AUTHORISED REPRESENTATIVES**

No agency commission is payable by University of Allahabad. Representatives in India of Foreign Manufacturers shall submit along with the tender (in technical bid) an Income Tax Clearance Certificate along with other relevant documents i.e. a copy of registration certificate from DGS&D in support of their being Representatives of the foreign manufacturers failing which their offer may not be considered.

**34. RIGHT OF ACCEPTANCE** The UNIVERSITY OF ALLAHABAD does not bind itself/himself to accept the lowest or any tender and reserves the right of accepting the whole or any part of the tender or a portion of the quantity offered. And the bidders shall supply the same at the rate quoted.

**35. PASSING OF PROPERTY** Property in the Stores shall not pass to the UNIVERSITY OF ALLAHABAD unless and until the equipment has been delivered, installed and accepted, in accordance with the conditions of the contract and to the entire satisfaction of the Council/UNIVERSITY OF ALLAHABAD.

**36. FREE SERVICE** Bidders are required to give full particulars of free service that would be given to the purchaser viz. UNIVERSITY OF ALLAHABAD during the period of Warranty and subsequently.

**37. PUBLICITY** Any publicity by the bidder in which the name of UNIVERSITY OF ALLAHABAD is to be used should be done only with the explicit written permission of UNIVERSITY OF ALLAHABAD.

**38. EMD:** The bidder has to deposit EMD as mentioned in the tender in the form of Demand draft/Bank guarantee as per performa in annexure II from a nationalized bank in favour of Finance officer, University of Allahabad along with their bid. EMD may be forfeited (a) if a bidder withdraws its bid during the period of bid validity specified by the bidder on the bid form Or (b) In case of a successful bidder, if the bidder fails to acknowledge and execute the order.

**39. OFFERS IN RESPECT OF PARTLY IMPORTED STORES AND PARTLY INDIGENOUS STORES** In case it is proposed to supply the stores partly imported and partly manufactured in this country, bidders are requested to indicate clearly in their tender full details of the components which are proposed to be manufactured in India and the components, which are proposed to be imported and their C.I.F price. The compatibility of equipments in these cases should be ensured by the supplier.

**40. INSURANCE** All the quoted stores shall be insured up to the place of delivery i.e. UoA stores. Charges for insurance should be mentioned separately in the Tender. The consignee will as soon as possible, but not later than 30 days of the date of arrival of stores at destination, notify the Supplier of any loss or damage to the stores that may have occurred during transit. In the event of contract being cancelled for any breach committed and the purchaser effecting re-purchase of the stores at the risk and cost of the supplier, the purchaser is not bound to accept the lower offer of Benami or allied or sister concern of the contractor.

**41. MANUFACTURING GUARANTEE:** The bidder shall be fully responsible for the manufacturer's warranty in respect of proper design, quality and workmanship of all the equipment accessories etc. covered by the tender for a period of 12 months from the date of satisfactory installation of the system. **The provision for extended warranty with terms and condition thereof, if any, may also be specifically mentioned.** Warranty regarding the quality shall be given as per Performa and should be signed by the bidder and enclosed with the offer. **The supplier will have to provide bank guarantee on execution on the contract performance agreement for 10% of the invoice value. The contract performance agreement should be valid during the course of warranty period.**

The equipment must conform to the highest quality and standard. All equipment, Hardware and related software, must be supplied with their original and complete printed documentation. Consistency must be maintained for the entire lot of the equipment offered. All the required quantity of an item in schedule of requirement must be of the same brand and same model number. Part numbers also must be same for all pieces of an item. The Bidder should not

## ENQUIRY FORM–HFIBF-DST (NANO MISSION)– OPEN GLOBAL TENDER

substitute any internal components or subsystems of equipment by similar items from a different manufacturer. All the equipment and peripherals should be supplied with the relevant interface cables

### 42.WARRANTY

- a. 3 years' onsite comprehensive warranty covering all parts & labour from the date of acceptance of the systems by University of Allahabad. During the warranty period, the bidder will have to undertake comprehensive maintenance of the entire equipment, including hardware, software, equipment and accessories supplied by the bidder at the site of installation.
- b. **The bidder having service center nearest to Allahabad to ensure that the machines are attended within a period of 24 hours after the complaint is lodged on working days, and within a period of 48 hours on holidays shall be preferred.**
- c. The Bidder shall be fully responsible for the manufacturer's warranty for all equipment, accessories, spare parts etc. against any defects arising from design, material, manufacturing, workmanship, or any act or omission of the manufacturer / Bidder or any defect that may develop under normal use of supplied equipment during the warranty period.
- d. The bidder shall also be responsible to ensure adequate regular supply of spare parts needed for a specific type of machinery and equipments whether under their annual maintenance and repairs rate contract or otherwise.
- e. Besides the above, the bidder will have to confirm the terms and conditions of warranty in **Annexure VII.**

### 43.EXCHANGE RATE VARIATION

- a. Bidders quoting for imported stores in Rupees on forward delivery basis should base their prices on a rate of exchange according to TT Selling rate as quoted by any authorized Exchange bankers supported by Reserve bank of India and Ruling on the date of tender. The base date and rate of exchange adopted for the tender should be invariably indicated in the tender.
- b. In the event of variation by more than 1 per cent (up or down) between the base rate and the rate of remittance to foreign Principals, the contract prices (limited only to that portion of the F.O.R. prices that are required to be remitted according to the contractual terms to the firm's foreign principal in foreign currency) will be subject to adjustment (up or down) in accordance with the TT selling rate of exchange as quoted by any authorized Exchange bankers ruling on the date the payment is made by the firm to their principals abroad which should not be beyond two weeks from the date on which initial payment is made by the purchaser to the contractor. No variation in price will, however, be allowed if the variation in the rate of exchange remains within the limit of 1 per cent plus or minus.
- c. No other charges will be affected by the change in the rate of exchange.

### 44.ORDER CANCELLATION University of Allahabad also reserves the right to cancel the order in the event of one or more of the following circumstances:

- a. Serious discrepancy in hardware noticed during the pre-dispatch inspection, if any.
- b. Breach by the bidder of any of the terms and conditions of the tender.
- c. Any action by the bidder which is in breach of law or accepted practices in commercial transactions
- d. If the Bidder goes into liquidation voluntarily or otherwise
- e. In addition to the cancellation of purchase order, University of Allahabad reserves the right to forfeit the Performance guarantee submitted to University of Allahabad by the Bidder and delisting the bidder.

### 45.COMPLETENESS OF THE CONTRACT

The contract will be deemed as incomplete if any component of the hardware, software, or any documentation / media relating thereto is not delivered, or is delivered but not installed and /or not operational or not acceptable to the Indenter after acceptance testing / examination. In such an event, the supply and installation will be termed as incomplete and it will not be accepted and the warranty period will not commence. The Warranty period will commence only on acceptance (based on acceptance test) of equipment by the Indenter.

### 46.INDEMNITY TO BANK

The Bidder should furnish a photocopy of the Agreement with their Principals in respect of all products offered. Further, the bidder shall indemnify University of Allahabad and keep indemnified against any loss or damage that the University of Allahabad may sustain on account of any violation of patents, trademark etc., by the bidder in respect of the products supplied.

## ENQUIRY FORM–HFIBF-DST (NANO MISSION)– OPEN GLOBAL TENDER

**47.ARBITRATION/ JURISDICTION:** All disputes or differences arising between the parties out of or relating to meaning and operation of effect of the contract or breach thereof shall be settled by arbitration in accordance with the rules and regulations of arbitrator. In case of any legal dispute the jurisdiction will be Allahabad only. University of Allahabad and the bidder shall make every effort to resolve amicably, by direct informal negotiation, any disagreement or dispute arising between them under or in connection with the contract. If after thirty days from the commencement of such informal negotiations, University of Allahabad and the Bidder have been unable to resolve amicably a contract dispute; either party may require that the dispute be referred for resolution by formal arbitration. The Vice Chancellor, University of Allahabad shall appoint a Sole Arbitrator of the dispute who will not be related to the contract and whose decision shall be final and binding on both the parties.

Yours faithfully,

Date \_\_\_\_\_  
Place \_\_\_\_\_

Registrar,  
UNIVERSITY OF ALLAHABAD,

**THE BIDDER SHALL SIGN EACH AND EVERY PAGE OF THE TENDER DOCUMENT AND ANNEX IT WITH THE TECHNICAL BID.**

SIGNATURE AND PARTICULARS OF BIDDER ■

ABBREVIATIONS	EXPANSION
1. CIF	Cost Insurance & Freight
2. UoA	University of Allahabad
3. DGS&D	Director General of Supplies & Disposal
4. EMD	Earnest Money Deposit
5. FAS	Free alongside Ship
6. FOB	Free on Board
7. FOR	Free on Rail
8. L/C	Letter of Credit
9. NSIC	National Small Scale Industries Corporation



## ENQUIRY FORM–HFIBF-DST (NANO MISSION)– OPEN GLOBAL TENDER

### QUESTIONNAIRE-I

1.	NAME AND ADDRESS OF SUPPLIER		
2.	Whether enlisted with DGS&D for subject stores along with foreign manufacturer	Yes	No
	Validity date of Regn/Enlistment Certificate		
3.	Whether past supplier of the subject stores to Ministry of Water Resources or any Government organization/undertaking during the last three year (if yes, submit the performance statement in the enclosed Performa)		
4.	Term of Delivery		
i)	FOB (Indicate the name of port of shipment)		
ii)	CIF (indicate the name of the airport)		
iii)	FOR destination		
6.			
a)	Whether sales tax extra in respect of locally manufactured stores		
b)	If yes the rate of Central Sales Tax (CST) & Local Sales Tax (LST) to be indicated		
7.	Discount offered, if any		
8.	Delivery period proposed and monthly rate of supply		
9.			
a)	Whether stores fully conforms to the tender schedule specification		
b)	If no, indicate the details of deviation on separate sheet		

Signature of the Bidder  
Name in Block Letters  
Capacity in which Tender Signed  
Full Address

# ENQUIRY FORM–HFIBF-DST (NANO MISSION)– OPEN GLOBAL TENDER

## QUESTIONNAIRE-II

BIDDERS SHOULD FURNISH SPECIFIC ANSWER TO ALL THE QUESTIONS GIVEN BELOW. BIDDERS MAY PLEASE NOTE THAT IF THE ANSWER SO FURNISHED ARE NOT CLEAR AND /OR ARE EVASIVE, THE TENDER WILL BE LIABLE TO BE REJECTED

- | Sl. No. | Question   |
|---------|--|
| 1.      | Tender Enquiry No.   |
| 2.      | Whether the stores offered fully confirm to the technical particulars and specification/drawings specified in the schedules to tender. If not whether the details of deviations have been mentioned in the proforma for the statement of deviations  |
| 3.      | Brand of the stores offered  |
| 4.      | Name and Address of Manufacturer   |
| 5.      | Place of Manufacture   |
| 6.      | Please confirm whether the store (s) will be supplied with packing and marking clause stipulated in the tender enquiry   |
| 7.      | Gross weight of the consignment and net weight of each item  |
| 8.      | Details of the Permanent Income Tax account no. of foreign manufacturer and the Indian Representative  |
| 9.      | Whether the latest Income Tax Clearance Certificate has been attached  |
| 10.     | What is the status of the supplier   |
| 11.     | Whether Indian Representative is registered with DGS&D under the compulsory enlistment scheme along with the foreign manufacturer, if so the details of the registration may be furnished  |
| 12.     | Whether Indian Representative is enlisted with the DGS&D under the compulsory enlistment scheme along with the foreign manufacturer, if so the details of the enlistment may please be furnished   |
| 13.     | Name and full address of the Banker to the foreign manufacturer and the Indian Representative.   |
| 14.     | Business name and the constitution of the firm/Indian Representative;<br>Is the firm is registered under the (a) Indian Company Act (b) Indian Partnership Act (c) any other act. If not please give the full name(s) and address(es) of the owner(s)  |
| 15.     | Whether the tendering firm is/are<br>a) manufacturer<br>b) Manufacturer's authorized Representative<br>c) Holders in stock of the stores tendered for<br>N.B.: If manufacturer's authorized Representative please enclose with the tender the copy of manufacturer's authorization/agency agreement.   |
| 16.     | If stores offered are manufactured in India, please state whether all the raw materials, components etc. used in the manufacturing are also produced in India. If not give details of the materials, components etc. that are imported and the break-up of the indigenous and imported components together with their value and proportion it bears to the total value of the store should also be given.  |
| 17.     | If partnership firm please state whether the firm is registered or not registered under Indian Partnership Act, 1932. Should the answer to this question by a partnership firm be in the affirmative, please state further<br>a) Whether by the partnership agreement, authority to refer disputes concerning the business of the partnership to arbitration has been conferred on the partner who has signed the tender.<br>b) If the answer to (a) above is in the negative whether there is any general power of attorney executed by all the partners of the firm authorizing the partner who has signed the tender to refer dispute concerning business of the partnership to the arbitration<br>c) If the answer to either (a) or (b) above is in the affirmative please furnish a copy of either the partnership agreement or the general power of attorney as the case may be.<br>N.B.:<br>1) Please attach to the tender a copy of either document on which reliance is placed for authority of partners or the partner signing the tender to refer disputes to arbitration. The copy should be attested by a Notary Public or its execution should be admitted by Affidavit on a properly stamped paper by all the |

## ENQUIRY FORM–HFIBF-DST (NANO MISSION)– OPEN GLOBAL TENDER

- partners.
- 2) Where authority to refer disputes to arbitration has not been given to the partner signing the tender the tenders must be signed by every partner of the firm.
18. Here state specifically
- Whether the price tendered by you is to the best of your knowledge and belief, not more than the price usually charged by you for stores of same nature/class or description to any private purchaser either foreign or as well as Government purchaser. If not state the reasons thereof if any, also indicate the margin of difference.
  - In respect of indigenous items for which there is a controlled price fixed by law, the price quoted shall not be higher than the controlled price and if the price quoted exceeds the controlled price the reasons thereof should be stated.
19. Are you:
- Holding valid Industrial License(s) Registration Certificate under the Industrial Development and Regulation Act, 1981. If so, please give particulars of Industrial Income Registration Certificate;
  - Exempted from the licensing provision of the act, for the manufacture of item quoted against this tender. If so, please quote relevant orders and explain your position
  - Whether you possess the requisite license for manufacture of the stores and/or for the procurement of raw materials belong to any controlled category required for the manufacture of the store? In the absence of any reply it would be assumed that no license is required for the purpose of raw materials and/or that you possess the required licence.
20. Please indicate here prices on the following basis:
- Net ex-factory price
  - Net FOB/FAS price exclusive of the commission
  - FAS Port of shipment of the principal/manufacturer price
  - FOB price
  - CIF Indian Port Price
  - F.O.R. Station of dispatch price (also indicating the station of dispatch)
  - F.O.R. Destination Price
21. In case of foreign firm quoting directly please indicate:  
The name of the Indian Representative(s)/Associates(s) for after sale service in India.
22. What is the precise relationship between the foreign manufacturer/principal and the India/Representative/Associates;
- The mutual interest which the manufacturer/principal abroad whether as a commission for the contract or as a general retainer fee;
  - Indian Representative's permanent Income Tax Account No.
  - The foreign principals/manufacturer's permanent Income Tax Account No.
  - Whether certificate has been furnished that the net prices are exclusive of commission/profit etc. to be paid to the principal/manufacturer in foreign currency and the amount of the agency commission which the Indian Representative(s) Associate(s) are entitled in terms of the agreement with the foreign principal has been indicated separately.
23. Please confirm that you have read all the instructions carefully and have complied with the instructions accordingly.

### Signature of the Witness:

Full name and address of the Witness in block letters

### Signature of the Bidder

I) Full name and address of the person signing (in block letters)  
II) Whether signing as proprietor/partner /Constituted Attorney/Duly authorized by the company.

## **ENQUIRY FORM–HFIBF-DST (NANO MISSION)– OPEN GLOBAL TENDER**

### **QUESTIONNAIRE-III**

#### **PROFORMA FOR EQUIPMENT AND QUALITY CONTROL OF THE MANUFACTURING FIRM**

Tender no..... Date of opening.....

Name of the Bidder.....

(Note : all details should relate to the manufacturer for items tendered for )

#### **S.No.**

1. Name & full address of the manufacturer
2. i) Telephone No. (iii) E.mail  
ii) Fax No.
3. Telegraphic address
4. Location of the manufacturing factory
5. Details of the Industrial license, wherever required as per statutory regulations
6. Details of important plant & machinery functioning in each department (monograph & description pamphlets be supplied, if available
7. Details of the process of manufacture in the factory
8. Details of stock of raw materials held
9. Production capacity of item(s) quoted for with the existing plant & machinery  
i) Normal  
ii) Maximum
10. Details of the arrangement for quality control of products such as laboratory testing equipments etc.
11. Whether goods are tested to any standard specification. If yes, copies or original test certificates should be submitted in triplicate
12. Are you registered/ enlisted with Directorate General of Supplies & Disposals (DGS&D), Government of India, if so full particulars of registration/enlistment, period of validity etc. with a copy of the registration/enlistment certificate may please be attached.

SIGNATURE OF THE MANUFACTURER

# ENQUIRY FORM–HFIBF-DST (NANO MISSION)– OPEN GLOBAL TENDER

## Annexure I

(NOTE: Letter to the University on the bidder's LETTER-HEAD)

Date:

To  
The Registrar  
University of Allahabad  
Allahabad-211002

Dear Sir,

Sub: Your tender for **Supply & Installation of "Full Permanent Magnet ECR In Source (ECRIS) mounted in a 300 kV platform"-your Enquiry No: UoA/DST/NanoMission/Sci-Equip-1/2015, dated 21.05.2015**

With reference to the above tender, having examined and understood the instructions, terms and conditions forming part of the tender, we hereby enclose our offer for the supply of the following items as detailed in your above referred tender.

Basic Item No.	Item Description	Make & Model

We further confirm that the offer is in conformity with the terms and conditions as mentioned in your above referred letter and enclosures. We also understand that the University is not bound to accept the offer either in part or in full and that the University has right to reject the offer in full or in part without assigning any reasons whatsoever.

We have enclosed the required bank guarantee favoring University of Allahabad issued by the ..... (Bank), .....(Branch),..... (Date), and is payable at Allahabad, towards **Earnest Money Deposit**.

Yours faithfully,

Authorized Signatories  
(Name & Designation, seal of the firm) Date:

## ENQUIRY FORM–HFIBF-DST (NANO MISSION)– OPEN GLOBAL TENDER

### Annexure II

(NOTE: This EMD bank guarantee certificate should be prepared on a NON JUDICIAL STAMP PAPER of Rs. 10/-)

#### **Earnest Money Deposit Bank Guarantee**

To  
The Registrar  
University of Allahabad  
Allahabad-211002

Dear Sir,

**Subject: Your Tender for Supply & Installation of "Scattering Chamber for ECR Ion Source\_HFIB Facility"- -your Enquiry No: UoA/DST/NanoMission/Sci-Equip/2015, dated: 21.05.2015.**

#### WHEREAS

The University of Allahabad located at Allahabad (hereinafter called the University) has invited tenders for the Supply & Installation of "**Scattering Chamber for ECR Ion Source\_HFIB Facility**"-on the terms and conditions mentioned in the tender document.

1. It is one of the terms of invitation of tenders that the bidder shall furnish a Bank Guarantee as detailed in the tender document Clause 6 as Earnest Money Deposit.

2. M/s \_\_\_\_\_, (hereinafter called as bidder), who are our constituents intend to submit their tender for the said equipments and have requested us to furnish guarantee to the 'University' in respect of the said sum of Rs. ----- / (Rupees----- only)

#### **NOW THIS GUARANTEE WITNESSETH**

1. We \_\_\_\_\_ (NAME OF THE BANK) do hereby agree with and undertake to the University of Allahabad, their Successors, Assigns that in the event of the University of Allahabad coming to the conclusion that the Bidder have not performed their obligations under the said conditions of the tender or have committed a breach thereof, which conclusion shall be binding on us as well as the said Bidder, we shall on demand by the University of Allahabad, pay without demur to the University of Allahabad, a sum of Rs. -----/(Rupees -----only) or any lower amount that may be demanded by the University of Allahabad. Our guarantee shall be treated as equivalent to the Earnest Money Deposit for the due performance of the obligations of the Bidder under the said Conditions, provided, however, that our liability against such sum shall not exceed the sum of Rs. -----/(Rupees ----- only).

2. We also agree to undertake to and confirm that the sum not exceeding Rs. ----- / (Rupees -----only) as aforesaid shall be paid by us without any demur or protest, merely on demand from the University of Allahabad on receipt of a notice in writing stating the amount is due to them and we shall not ask for any further proof or evidence and the notice from the University of Allahabad shall be conclusive and binding on us and shall not be questioned by us in any respect or manner whatsoever.

**We undertake to pay the amount claimed by the University of Allahabad within a period of one week from the date of receipt of the notice as aforesaid.**

3. We confirm that our obligation to the University of Allahabad under this guarantee shall be independent of the agreement or agreements or other understandings between the University of Allahabad and the Bidder.

**This guarantee shall not be revoked by us without prior consent in writing of the University of Allahabad.**

**We hereby further agree that**

**ENQUIRY FORM–HFIBF-DST (NANO MISSION)– OPEN GLOBAL TENDER**

Any forbearance or commission on the part of the University of Allahabad in enforcing the conditions of the said agreement or in compliance with any of the terms and conditions stipulated in the said tender and/or hereunder or granting of any time or showing of any indulgence by the University of Allahabad to the Bidder or any other matters in connection therewith shall not discharge us in any way our obligation under this guarantee. This guarantee shall be discharged only by the performance by the Bidders of their obligations and in the event of their failure to do so, by payment by us of the sum not exceeding Rs. -----  
-- (Rupees -----only)

Our liability under these presents shall not exceed the sum of Rs. -----  
(Rupees -----only)

Our liability under this agreement shall not be affected by any infirmity or irregularity on the part of our said constituents in tendering for the said work or their obligations there under or by dissolution or change in the constitution of our said constituents.

This guarantee shall remain in force upto .....provided that if so desired by the University of Allahabad, this guarantee shall be renewed for a further period as may be indicated by them on the same terms and conditions as contained herein.

Our liability under this presents will terminate unless these presents are renewed as provided hereinabove on the .....or on the day when our said constituents comply with their obligations, as to which a certificate in writing by the University of Allahabad alone is the conclusive proof whichever date is later. Unless a claim or suit or action is filed against us within six months from that date or any extended period, all the rights of the University of Allahabad against us under this guarantee shall be forfeited and we shall be released and discharged from all our obligations and liabilities hereunder.

Yours' faithfully,  
For and on behalf of \_\_\_\_\_ Bank  
Authorized official

**(Note:** This guarantee will require stamp duty as applicable and shall be signed by the official whose signature and authority shall be verified).

## ENQUIRY FORM–HFIBF-DST (NANO MISSION)– OPEN GLOBAL TENDER

### Annexure III

**(NOTE: This letter of authority should be on the Letter-Head of the manufacturing concern and should be signed by a competent person of the manufacturer)**

#### **Manufacturer's Authorization Form (MAF)**

Ref: No. **Your Tender for Supply & Installation of "Scattering Chamber for ECR Ion Source\_HFIB Facility"--your Enquiry No: UoA/DST/NanoMission/Sci-Equip/2015, dated 21.05.2015**

dated \_\_\_\_\_

To

The Registrar  
University of Allahabad  
Allahabad-211002

Dear Sir,

Tender Reference **UoA/DST/NanoMission/Sci-Equip-1/2015 dated: 21.05.2015**

We \_\_\_\_\_  
who are established and \_\_\_\_\_ having factories at  
reputable manufacturers of \_\_\_\_\_  
and  
do \_\_\_\_\_ hereby authorize M/s  
(Name and address of Agent/Dealer) to offer  
their quotation, negotiate and conclude the contract with you against the above invitation for  
tender offer.

We hereby extend our full guarantee and warranty as per terms and conditions of  
the tender and the contract for the equipment and services offered against this invitation for  
tender offer by the above firm.

Yours faithfully, Authorized Signatories  
(Name & Designation) Date:

For and on behalf of M/s \_\_\_\_\_  
(Name of manufactures)



## ENQUIRY FORM–HFIBF-DST (NANO MISSION)– OPEN GLOBAL TENDER

### Annexure IV

**(NOTE: This letter of authority should be on the Letter-Head of the manufacturing concern and should be signed by a competent person of the manufacturer)**

Ref: No. **Your Tender for Supply & Installation of "Scattering Chamber for ECR Ion Source\_HFIB Facility"--your Enquiry No: UoA/DST/NanoMission/Sci-Equip/2015, dated: 21.05.2015**

**Details filled in this form must be accompanied by sufficient documentary evidence, in order to verify the correctness of the information.**

S. No	Item	Details
1	Name of Company	
2	Mailing Address	
3	Telephone and Fax numbers	
4	Date of registration of the Company	
5	Year of commencement of Business	
6	Name and designation of the person authorized to make commitments to the University	
7	Contact details of the person authorize to make commitments to the University	
8	Turn over of the company 2008-2009 2009-2010 2010-2011 2011-2012 2012-2013 2013-2014	
9	Profit of the company 2008-2009 2009-2010 2010-2011 2011-2012 2012-2013 2013-2014	
10	Sales Tax TIN/TAN Number	
11	Income Tax Number	
12	Whether direct manufacturer or authorized dealers	

Signature (Name & Designation)

Date:

## **ENQUIRY FORM–HFIBF-DST (NANO MISSION)– OPEN GLOBAL TENDER**

### **Annexure V**

**(NOTE: This letter of authority should be on the Letter-Head of the manufacturing concern and should be signed by a competent person of the manufacturer)**

### **CERTIFICATE FROM THE BIDDER STATING THAT THE COMPANY HAS NOT BEEN BLACKLISTED BY ANY GOVERNMENT ORGANISATION**

The Registrar  
University of Allahabad  
Allahabad 211002

Ref: No. **Your Tender for Supply & Installation of "Scattering Chamber for ECR Ion Source\_HFIB Facility"--your Enquiry No: UoA/DST/NanoMission/Sci-Equip/2015, dated: 21.05.2015**

Dear Sir,

This is to certify that M/s \_\_\_\_\_ has not been blacklisted by any Government Organization before submission of the tender document.

Yours faithfully,  
Authorized Signatories

(Name & Designation)  
Date:

For and on behalf of M/s \_\_\_\_\_

**Annexure VI**

**(NOTE: This letter of authority should be on the Letter-Head of the manufacturing Concern and should be signed by a competent person of the manufacturer.)**

To

**The Registrar  
University of Allahabad  
Allahabad-211002**

Ref: No. **Your Tender for Supply & Installation of "Scattering Chamber for ECR Ion Source\_HFIB Facility"--your Enquiry No: UoA/DST/NanoMission/Sci-Equip/2015, dated: 21.05.2015**

Dear Sir,

**We hereby certify that we have executed the following 3 projects to completion on the similar items (.....) as offered in the present tender to other Government organizations/Educational Institutions/Universities/Govt. Research Organizations.**

**Note:** Please quote only those projects which are of substantial value.

Name of the Bidder \_\_\_\_\_

<b>S. No.</b>	<b>Name of the Client</b>	<b>Equipment</b>	<b>Clients Contact Details (Including Name, E-mail, Phone and Fax No. and Proper Address)</b>	<b>Remarks</b>

Signature (Name & Designation)  
Date:

**ENQUIRY FORM–HFIBF-DST (NANO MISSION)– OPEN GLOBAL TENDER**

**Annexure VII**

**(NOTE: This letter of authority should be on the Letter-Head of the manufacturing Concern and should be signed by a competent person of the manufacturer.)**

**To**

**The Registrar  
University of Allahabad  
Allahabad-211002**

Ref: No. **Your Tender for Supply & Installation of "Scattering Chamber for ECR Ion Source\_HFIB Facility"--your Enquiry No: UoA/DST/NanoMission/Sci-Equip/2015, dated 21.05.2015**

**Details of Support and Service Centers**

Name of the Bidder \_\_\_\_\_

S. No.	Place	Own Office/Franchise	Postal Address	Contact Person & Contact Details	Number of Engineers	Service Facilities available (Describe in detail)

Signature (Name & Designation)

Date:

**Annexure VIII**

**(NOTE: This letter of authority should be on the Letter-Head of the manufacturing concern and should be signed by a competent person of the manufacturer.)**

**Warranty Compliance Statement**

The Registrar  
University of Allahabad  
Allahabad-211002

Dear Sir,

Subject: **Tender for Supply & Installation of "Scattering Chamber for ECR Ion Source\_HFIB Facility"--your Enquiry No: UoA/DST/NanoMission/Sci-Equip/2015, dated 21.05.2015**

This bears reference to our quotation Ref\_\_\_\_\_Dated \_\_\_\_\_.

We warrant that everything to be supplied by us shall be brand new, free from all defects and faults in material, workmanship and manufacture and shall be of the highest grade, quality and consistent with the established standards for materials specification, drawings or samples, if any, and shall operate properly. We shall be fully responsible for its efficient operation.

We also confirm that all service related complaints for the ..... will be attended within a period of 24 hours after the complaint is lodged on working days, and within a period of 48 hours on holidays.

During the warranty period in case of failing to repair the machine, we will provide a stand-by arrangement till the equipment is repaired.

Yours faithfully  
Signature (Name & Designation)  
Date:

## ENQUIRY FORM–HFIBF-DST (NANO MISSION)– OPEN GLOBAL TENDER

### Annexure IX

**(NOTE: This letter of authority should be on the Letter-Head of the manufacturing concern and should be signed by a competent person of the manufacturer.)**

(To be enclosed in a similar format along with the offer)

### TECHNICAL COMPLIANCE SHEET FORMAT

The Registrar  
University of Allahabad  
Allahabad-211002

**Subject: Tender for Supply & Installation of "Scattering Chamber for ECR Ion Source\_HFIB Facility"--  
your Enquiry No: UoA/DST/NanoMission/Sci-Equip/2015, dated 21.05.2015**

Dear Sir,

**The TECHNICAL COMPLIANCE SHEET** is being furnished as per below;

**[Please note:**

1. Compliance/Deviation statement comparing the specifications of the quoted model to the required specifications. This statement should also give the page number(s) of the technical literature where the relevant specification is mentioned.
2. Bids must have supporting documents (technical literature or copies of relevant pages from the service manual or factory test data) for all the points noted above, failure regarding which may result in rejection of bid. In case of NO DEVIATION please sign and send the document with the comment "NO DEVIATION".]

ITEM NAME	"Scattering Chamber for ECR Ion Source_HFIB Facility"		
S.No	Tender Specifications	Bidder's Specifications	Remarks/Deviation If any
		<b>USE SEPARATE SHEET, if required</b>	
	<p><b>GENERAL SPECIFICATIONS:</b> <b>GENERAL SPECIFICATIONS:</b> The scattering chamber will be connected with beam line from a Full Permanent Magnet ECR In Source (ECRIS) mounted in a 300 kV platform. The <b>Scattering Chamber</b> shall be preferred that includes the chamber with hydraulic lifting lid, sample holders, vacuum component (including turbo molecular and dry pumps, gauges), goniometer head having -Y-Z-θ and φ rotation with command and control, software and all ancillary equipment for running the facility. <b>If applying for one sub system or only few components the bidder should clearly mention the novelty and advantages of theirs as why one should prefer them against other.</b> Allahabad University will provide all conditions for smooth installation, including water, electricity, compressed air and equipments necessary for lifting and moving the components for installation. However, complete specifications for pre installation requirements relating to successful commissioning and operation of equipment such as power lines, HV insulation transformer, Water cooling unit, Ground, LAN etc must be provided with the Technical bid in advance. The bidder should also provide full documentation including the necessary drawings for maintenance and training of at least 3 operators. All drawings of the final system should be approved by the Contracting authority.</p> <p><b>SPECIFICATIONS OF VARIOUS EQUIPMENTS:</b></p> <ol style="list-style-type: none"> <li>1. The draft drawing of the experimental chamber is given in <b>FIGURE 1</b> (ONLY INDICATIVE). Vacuum should be guaranteed for <math>1 \times 10^{-9}</math> Torr. All flanges should be standard CF. The sample holders must be capable of following: <ol style="list-style-type: none"> <li>i. For irradiation of large number of samples arranged and optimised on a ladder (both side) in such a way that without affecting the vacuum system a number of</li> </ol> </li> </ol>		

## ENQUIRY FORM–HFIBF-DST (NANO MISSION)– OPEN GLOBAL TENDER

- samples could be remotely seen and moved for implantation purposes.
- ii. For nano-structuring, uniform implantation (comparing and contrasting as in case of PIII), the sample mounted on goniometer head should be capable of receiving the beam for designated movements with variable speeds in x-y-z directions, remotely monitored and manipulated in prescribed direction. The goniometer head should be of following specifications or better:  
Adjustable axes:  $R\theta$ ,  $R\phi$ , Y, X, Z, Range X (mm): +/- 3, Range Y (mm): +/- 3, Range Z (mm): 2.5, Range  $R\theta$  (°): + 80 ... - 30, Range  $R\phi$  (°): +/- 17, Read out accuracy (°): 0.1
  - iii. The possibility for movement of samples from one chamber to other with the help of manipulators without breaking the experimental conditions.
  - iv. The possibility for varying the temperature of sample during the irradiation. Must to operate with closed cycle cryogenic system for sample temperature variation from less than 20K to 300K and high temperature oven 300K to 1273K with respect to time, field and low and high temperature. It should consist of closed loop variable temperature cryostat and high temperature furnace with temperature controller. Closed cycle cryogenic system with cooling power of 5 watt at 20K and with Beryllium copper sample chamber. The variable temperature cryostat should be capable of generating temperatures in the range of 80-400 K with the temperature accuracy of +1 K. Lower temperature capability is preferred. Low temperature Cryostat usable with liquid nitrogen or liquid helium and temperature variation continuously from 77K or 4.5k to 300K The high temperature oven should be capable of generating temperatures in the range of RT - 1200 K or better with temperature accuracy of + 1 K. Higher temperature capabilities are preferred. Combined cryostat and oven for the temperature variation from 77K to 900K, with LN2 the temperature variation from 77 K to 300K sable measurements should be at 77K, 90K continuous to 300k.
  - v. The desirability of ii and iv simultaneously could also be worked out.
  - vi. Two gate valves for Ultra High Vacuum (UHV) with stainless steel bellows sealed: Gate Valve Optional Features include: Modular electromechanical position indicators, Air **control** solenoid valves, stainless steel bellows, High body roughing ports and High temperature. They must be bellows sealed and their mechanism should be free of lubricants.
2. **Vacuum components:** Vacuum components, including Turbo-molecular pumps, Cryogenic pumps, mechanical pumps, connections, vacuum measurements, bellows, isolation valves and vacuum measurements must be provided. Remote control is not required, but remote vacuum measurements should be included in the Command and Control system. The vacuum pressure in the experimental chamber (without beam) should be of  $1 \times 10^{-9}$

## ENQUIRY FORM–HFIBF-DST (NANO MISSION)– OPEN GLOBAL TENDER

Torr.

3. **Portable He gas leak detector system:** The detection range of Helium in vacuum tests lies between  $10^{-2}$  and  $10^{-11}$  Pa.m<sup>3</sup>/s or better.
4. **Documentation:** Operation & Service manuals in Duplicate: Full documentation of all components should be provided in English. The documentation should include functional description, maintenance procedure and troubleshooting, Diagrams of electrical wiring & interconnections and Electronic Circuits (including those of sub assemblies), Spatial and temporal mapping related to measurements of emanating radiations from the equipment and any warning or mitigation issue during the operation or maintenance of equipment, in Duplicate.
5. **Installation and training:** The installation of the whole system should be executed by the bidder. The Contracting authority will provide substantial help and all local conditions for the installation provided all the inputs relating to technical specifications for the same is furnished along with the technical bid by the bidder. The training should be included that will occur in the final place of the equipment, after final tests. The installation and commissioning will be carried out at UOA, ALLAHABAD by the firm's engineers. Special utility requirements, such as, vibration free platform, power points, cooling water, LN2 consumption, etc., should be informed well in advance for necessary site preparation.
6. **Quality:** The bidder should demonstrate ultimate vacuum achieved in scattering chamber. This test should be done in the factory and at on-site after the installation. Conditions for the tests and acceptance will be mutually agreeable between contracting authority and the bidder.
7. **Guarantee/Warranty**  
The complete system must be guaranteed for free repair/replacement for a minimum period of five year from the date of acceptance. Software up gradation, if any, has to be incorporated free of cost during the warranty period.
8. **The itemized details of the equipment and its components** must contain the technical specifications **(and their itemized prices in financial bid)** to be able to compare, contrast and select as per the project objectives for example:

j) The system should be complete with power supplies, controls for remote operation, cooling lines and cabling.

#### **Operational Power Supply**

The system should be designed to operate on 220VAC  $\pm$  10%, 50 Hz, 1 Phase or 380 VAC  $\pm$  10%, 50 Hz, 3 Phase.

**Spares (To be included as optional)** The bidder should include in the quotation adequate spares for two years of trouble free operation of the system.

Electronic spares like ICs, relays, PCBs, transistors, Hall Probes, Pick-up coils, temperature sensors, thermocouples, sample holders (rods, cups etc.), oven assemblies, slow / fast blow fuses, HRC fuses

#### **USE SEPARATE SHEET FOR FOLLOWING**

The itemized details of the equipment and its components must contain the technical specifications **(and their itemized prices in financial bid)** to be able to compare, contrast and select as per the project objectives for example:



**ENQUIRY FORM-HFIBF-DST (NANO MISSION)- OPEN GLOBAL TENDER**

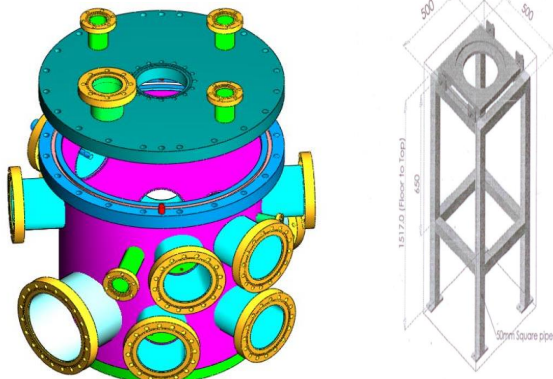

**FIGURE -1**

**Important: Please provide a compliance statement of the specifications along with the quotation by responding to each and every specification detailed as per above.**

(Technical literature/brochures/manuals should be attached along with this format)

Yours faithfully

Signature (Name & Designation)

Date:

## ENQUIRY FORM–HFIBF-DST (NANO MISSION)– OPEN GLOBAL TENDER

### Annexure X

**(NOTE: This letter of authority should be on the Letter-Head of the manufacturing concern and should be signed by a competent person of the manufacturer.)**

(To be enclosed in a similar format along with the offer- PRICE BID)

### PRICE BID FORMAT

The Registrar  
University of Allahabad  
Allahabad-211002

**Subject: Supply & Installation of "Scattering Chamber for ECR Ion Source\_HFIB Facility"--your Enquiry No: UoA/DST/NanoMission/Sci-Equip/2015, dated 21.05.2015**

Dear Sir,

**The** Price Bid with detailed itemized prices is being furnished as per the specifications provided in Tender document copied below. It is certified that the items / components quoted below are optimal in order to achieve the functionality described in Tender Document with special reference to the objectives of the project (Annexed with the Tender document);

**[Please note:**

ITEM NAME	<b>"Scattering Chamber for ECR Ion Source_HFIB Facility"</b>		
S.No.	Items	Itemised Price	Remarks, If any
	<p><b>GENERAL SPECIFICATIONS:</b> <b>GENERAL SPECIFICATIONS:</b> The scattering chamber will be connected with beam line from a Full Permanent Magnet ECR In Source (ECRIS) mounted in a 300 kV platform. The <b>Scattering Chamber</b> shall be preferred that includes the chamber with hydraulic lifting lid, sample holders, vacuum component (including turbo molecular and dry pumps, gauges), goniometer head having -Y-Z-θ and φ rotation with command and control, software and all ancillary equipment for running the facility. <b><i>If applying for one sub system or only few components the bidder should clearly mention the novelty and advantages of theirs as why one should prefer them against other.</i></b> Allahabad University will provide all conditions for smooth installation, including water, electricity, compressed air and equipments necessary for lifting and moving the components for installation. However, complete specifications for pre installation requirements relating to successful commissioning and operation of equipment such as power lines, HV insulation transformer, Water cooling unit, Ground, LAN etc must be provided with the Technical bid in advance. The bidder should also provide full documentation including the necessary drawings for maintenance and training of at least 3 operators. All drawings of the final system should be approved by the Contracting authority.</p> <p><b>SPECIFICATIONS OF VARIOUS EQUIPMENTS:</b></p> <ol style="list-style-type: none"> <li>1. The draft drawing of the experimental chamber is given in <b>FIGURE 1</b> (ONLY INDICATIVE). Vacuum should be guaranteed for <math>1 \times 10^{-9}</math> Torr. All flanges should be standard CF. The sample holders must be capable of following: <ol style="list-style-type: none"> <li>i. For irradiation of large number of samples arranged and optimised on a ladder (both side) in such a way that without affecting the vacuum system a number of samples could be remotely seen and moved for implantation purposes.</li> <li>ii. For nano-structuring, uniform implantation (comparing and contrasting as in case of PIII),</li> </ol> </li> </ol>		

## ENQUIRY FORM–HFIBF-DST (NANO MISSION)– OPEN GLOBAL TENDER

	<p>the sample mounted on goniometer head should be capable of receiving the beam for designated movements with variable speeds in x-y-z directions, remotely monitored and manipulated in prescribed direction. The goniometer head should be of following specifications or better: Adjustable axes: <math>R\theta</math>, <math>R\phi</math>, Y, X, Z, Range X (mm): +/- 3, Range Y (mm): +/- 3, Range Z (mm): 2.5, Range <math>R\theta</math> (<math>^{\circ}</math>): + 80 ... - 30, Range <math>R\phi</math> (<math>^{\circ}</math>): +/- 17, Read out accuracy (<math>^{\circ}</math>): 0.1</p> <p>iii. The possibility for movement of samples from one chamber to other with the help of manipulators without breaking the experimental conditions.</p> <p>iv. The possibility for varying the temperature of sample during the irradiation. Must to operate with closed cycle cryogenic system for sample temperature variation from less than 20K to 300K and high temperature oven 300K to 1273K with respect to time, field and low and high temperature. It should consist of closed loop variable temperature cryostat and high temperature furnace with temperature controller. Closed cycle cryogenic system with cooling power of 5 watt at 20K and with Beryllium copper sample chamber. The variable temperature cryostat should be capable of generating temperatures in the range of 80-400 K with the temperature accuracy of +1 K. Lower temperature capability is preferred. Low temperature Cryostat usable with liquid nitrogen or liquid helium and temperature variation continuously from 77K or 4.5k to 300K The high temperature oven should be capable of generating temperatures in the range of RT - 1200 K or better with temperature accuracy of + 1 K. Higher temperature capabilities are preferred. Combined cryostat and oven for the temperature variation from 77K to 900K, with LN2 the temperature variation from 77 K to 300K sable measurements should be at 77K, 90K continuous to 300k.</p> <p>v. The desirability of ii and iv simultaneously could also be worked out.</p> <p>vi. Two gate valves for Ultra High Vacuum (UHV) with stainless steel bellows sealed: Gate Valve Optional Features include: Modular electromechanical position indicators, Air control solenoid valves, stainless steel bellows, High body roughing ports and High temperature. They must be bellows sealed and their mechanism should be free of lubricants.</p> <p>2. <b>Vacuum components:</b> Vacuum components, including Turbo-molecular pumps, Cryogenic pumps, mechanical pumps, connections, vacuum measurements, bellows, isolation valves and vacuum measurements must be provided. Remote control is not required, but remote vacuum measurements should be included in the Command and Control system. The vacuum pressure in</p>		
--	---	--	--

## ENQUIRY FORM–HFIBF-DST (NANO MISSION)– OPEN GLOBAL TENDER

	<p>the experimental chamber (without beam) should be of 1 x 10<sup>-9</sup> Torr.</p> <ol style="list-style-type: none"> <li>3. <b>Portable He gas leak detector system:</b> The detection range of Helium in vacuum tests lies between 10<sup>-2</sup> and 10<sup>-11</sup> Pa.m<sup>3</sup>/s or better.</li> <li>4. <b>Documentation:</b> Operation &amp; Service manuals in Duplicate: Full documentation of all components should be provided in English. The documentation should include functional description, maintenance procedure and troubleshooting, Diagrams of electrical wiring &amp; interconnections and Electronic Circuits (including those of sub assemblies), Spatial and temporal mapping related to measurements of emanating radiations from the equipment and any warning or mitigation issue during the operation or maintenance of equipment, in Duplicate.</li> <li>5. <b>Installation and training:</b> The installation of the whole system should be executed by the bidder. The Contracting authority will provide substantial help and all local conditions for the installation provided all the inputs relating to technical specifications for the same is furnished along with the technical bid by the bidder. The training should be included that will occur in the final place of the equipment, after final tests. The installation and commissioning will be carried out at UOA, ALLAHABAD by the firm's engineers. Special utility requirements, such as, vibration free platform, power points, cooling water, LN2 consumption, etc., should be informed well in advance for necessary site preparation.</li> <li>6. <b>Quality:</b> The bidder should demonstrate ultimate vacuum achieved in scattering chamber. This test should be done in the factory and at on-site after the installation. Conditions for the tests and acceptance will be mutually agreeable between contracting authority and the bidder.</li> <li>7. <b>Guarantee/Warranty:</b> The complete system must be guaranteed for free repair/replacement for a minimum period of five year from the date of acceptance. Software up gradation, if any, has to be incorporated free of cost during the warranty period.</li> <li>8. <b>The itemized details of the equipment and its components</b> must contain the technical specifications <b>(and their itemized prices in financial bid)</b> to be able to compare, contrast and select as per the project objectives for example:             <ol style="list-style-type: none"> <li>j) The system should be complete with power supplies, controls for remote operation, cooling lines and cabling.</li> </ol> <p style="text-align: center;"><b>Operational Power Supply</b></p> <p>The system should be designed to operate on 220VAC ± 10%, 50 Hz, 1 Phase or 380 VAC ± 10%, 50 Hz, 3 Phase.</p> <p style="text-align: center;"><b>Spares (To be included as optional)</b></p> <p>The bidder should include in the quotation adequate spares for two years of trouble free operation of the system. Electronic spares like ICs, relays, PCBs, transistors, Hall Probes, Pick-up coils, temperature sensors, thermocouples, sample holders (rods, cups etc.), oven assemblies, slow / fast blow fuses, HRC fuses</p> <p style="text-align: center;"><b><u>USE SEPARATE SHEET FOR FOLLOWING</u></b></p> <p><b>The itemized details of the equipment and its components</b> must contain the technical specifications <b>(and their itemized prices in financial bid)</b> to be able to compare, contrast and select as per the project objectives for example:</p> </li> </ol>		
--	--	--	--

**ENQUIRY FORM-HFIBF-DST (NANO MISSION)- OPEN GLOBAL TENDER**

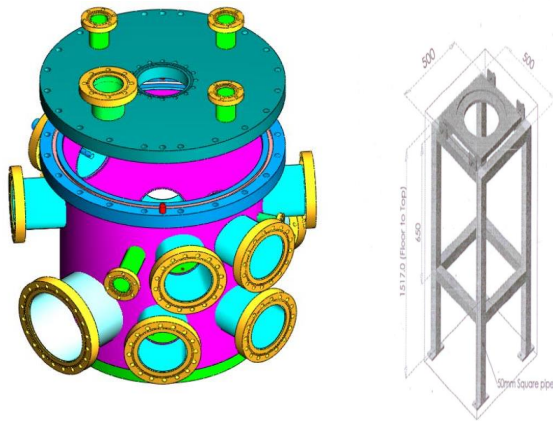

**FIGURE -1**

**Important: Please provide a compliance statement of the specifications along with the quotation by responding to each and every specification detailed as per above.**

The Commercial Offer (C.O) should give all relevant price information as per **Annexure X**. The Bid Form must be filled in completely, without any errors, erasures or alterations. The Commercial offer must not contradict the technical offer in any way.

Yours faithfully

Signature (Name & Designation)

Date:

**ENQUIRY FORM–HFIBF-DST (NANO MISSION)– OPEN GLOBAL TENDER**

**BRIEF SUMMARY OF QUOTATION**

**(Not To Be Used For Evaluation/Comparison Purpose)**

**IN CASE OF TWO BID SYSTEM ENCLOSE THIS PAGE WITH PRICE BID**

**(Please Fill It Up. DON'T Write 'AS PER QUOTATION' / 'PLEASE REFER TO OUR OFFER')**

<b>Quotation Ref. No.</b>		<b>Date</b>	
<b>01</b>	Main Item Model NUMBER		
<b>02</b>	Total FCA/FOB Value Of The Offered Package (Inclusive of Indian Agency Commission, if any)		
<b>03</b>	Insurance & Airfreight Charges		
<b>04</b>	CIF Value Of The Package		
<b>05</b>	Payment Terms <i>(Conditional Payment Terms Will NOT Be Accepted)</i>		
<b>06</b>	Delivery Time (Weeks/Months)		
<b>07</b>	Warranty (Months/Years)		
<b>08</b>	Validity of Quotation (Days/Months)		
<b>09</b>	Country of Origin (product)		
<b>10</b>	Port of Shipment		
<b>11</b>	Approx. Shipment Wt. (Chargeable Wt.) of The Item ( <b>Kg.</b> )		
<b>12</b>	Approx. Dimensions/Vol. of The Packed Consignment		
<b>10</b>	In Case of Two Bid System This Page Will Be Enclosed With The PRICE Bid.		

*We have read and understood the tender terms and conditions. The undersigned is competent to sign the tender document including this page on behalf of the quoting firm.*

Date

(Signature with Seal)

**ENQUIRY FORM–HFIBF-DST (NANO MISSION)– OPEN GLOBAL TENDER**

**CHECKLIST**

**(Not To Be Used For Evaluation/Comparison Purpose)**

**IN CASE OF TWO BID SYSTEM ENCLOSE THIS PAGE WITH TECHNICAL BID**

**(Please Fill It Up. DON'T Write 'AS PER QUOTATION' / 'PLEASE REFER TO OUR OFFER')**

<b>CHECKLIST</b>	<b>CHECKLIST</b>	<b>CHECKLIST</b>
<b>01</b>	Following Things Are Mentioned On The Main (Outer) Envelope Item Name /Reference No. /Last Date For Submission Of Tender/Date Of Opening Of Tender /Firm's Name & Address	
<b>02</b>	EMD Fee (DD) is <b>Enclosed</b> (With The Technical Bid Envelope In Case Of Two Bid.)	
<b>03</b>	Demand Draft(s) Is/Are In Favour Of Finance Officer, University of Allahabad And <b>Payable</b> At Allahabad. <b>Firm's Name/Ref. No. Etc. Has Been Mentioned On The Back Side of DDs.</b>	
<b>04</b>	The Bid Papers Have Been <b>PUNCHED</b> With A Hole <input checked="" type="checkbox"/> On The <b>Top Left Hand Corner Side</b> And <b>Properly Tagged and given page nos.</b>	
<b>05</b>	Total number of Pages PRICE BID TECHNICAL BID	
<b>06</b>	Prices have been quoted keeping in view <b>General &amp; Special Conditions. I/WE HAVE READ &amp; UNDERSTOOD THESE PARAS CAREFULLY.</b>	
<b>07</b>	The <b>Technical Compliance Statement</b> (As Per Annexure I) Has Been Enclosed.	
<b>08</b>	Only <b>Relevant</b> Documents (Technical Brochures/Leaflets Etc.) Required In Support Of The Quoted Item Have Been Enclosed. <b>No</b> Irrelevant Papers like ITCC, User Recommendations, and Order Copies etc. Have Been Enclosed Unless Specifically Asked For.	
<b>09</b>	Quotation Have Been Duly Signed And Stamped By The <b>Authorized &amp; Competent</b> Person. All Cuttings/Over Writings Have Been Duly Checked, Initialed And Stamped. (If Applicable)	
<b>10</b>	In Case of Two Bid System This Page Will Be Enclosed With The TECHNICAL Bid.	
<b>11</b>	<b>QUESTIONNAIRE-I, II&amp; II, And Annexures 1 to 10.</b>	

*We have read and understood the tender terms and conditions. The undersigned is competent to sign the tender document including this page on behalf of the quoting firm.*

Date

(Signature with Seal)